

SALES DRAWING

SALES DRAWING

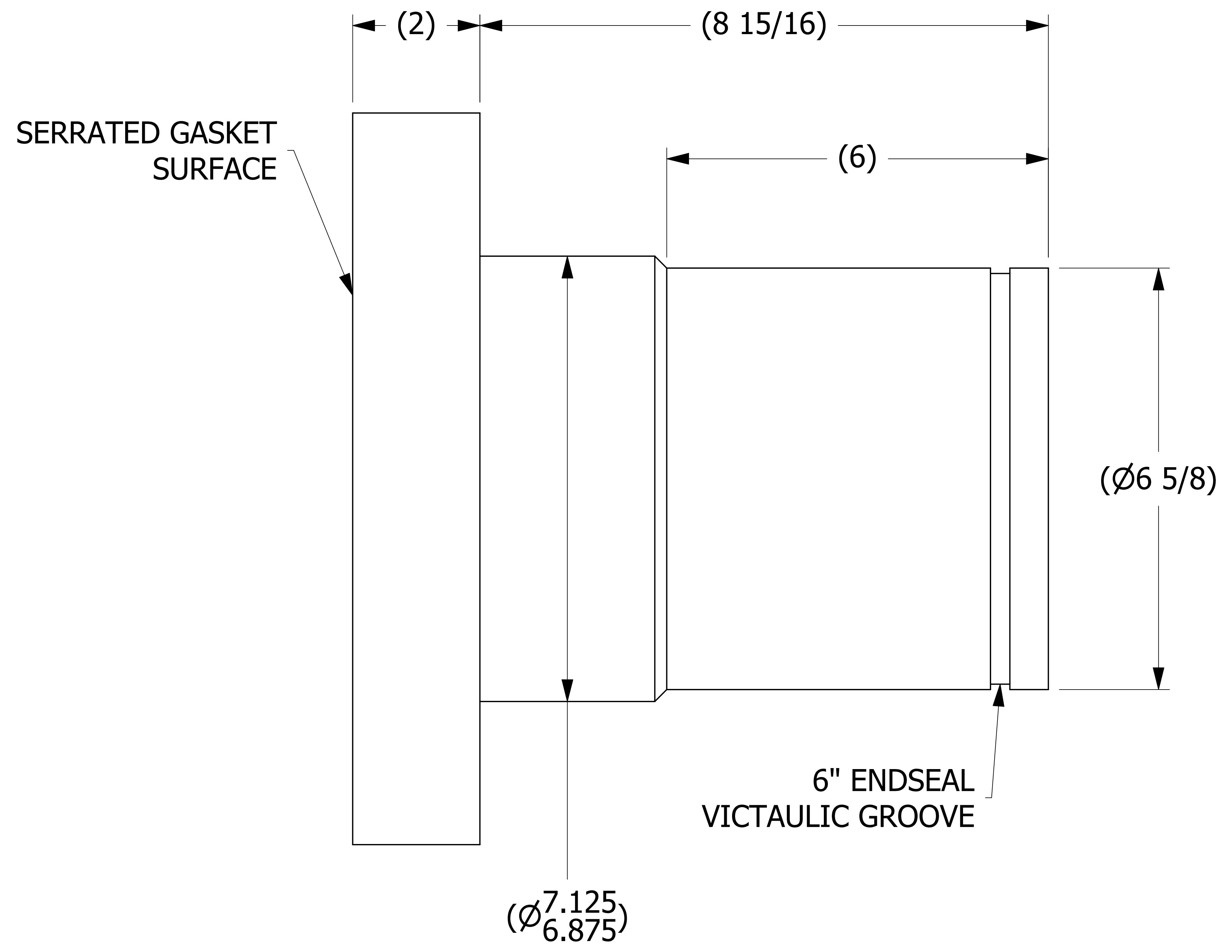
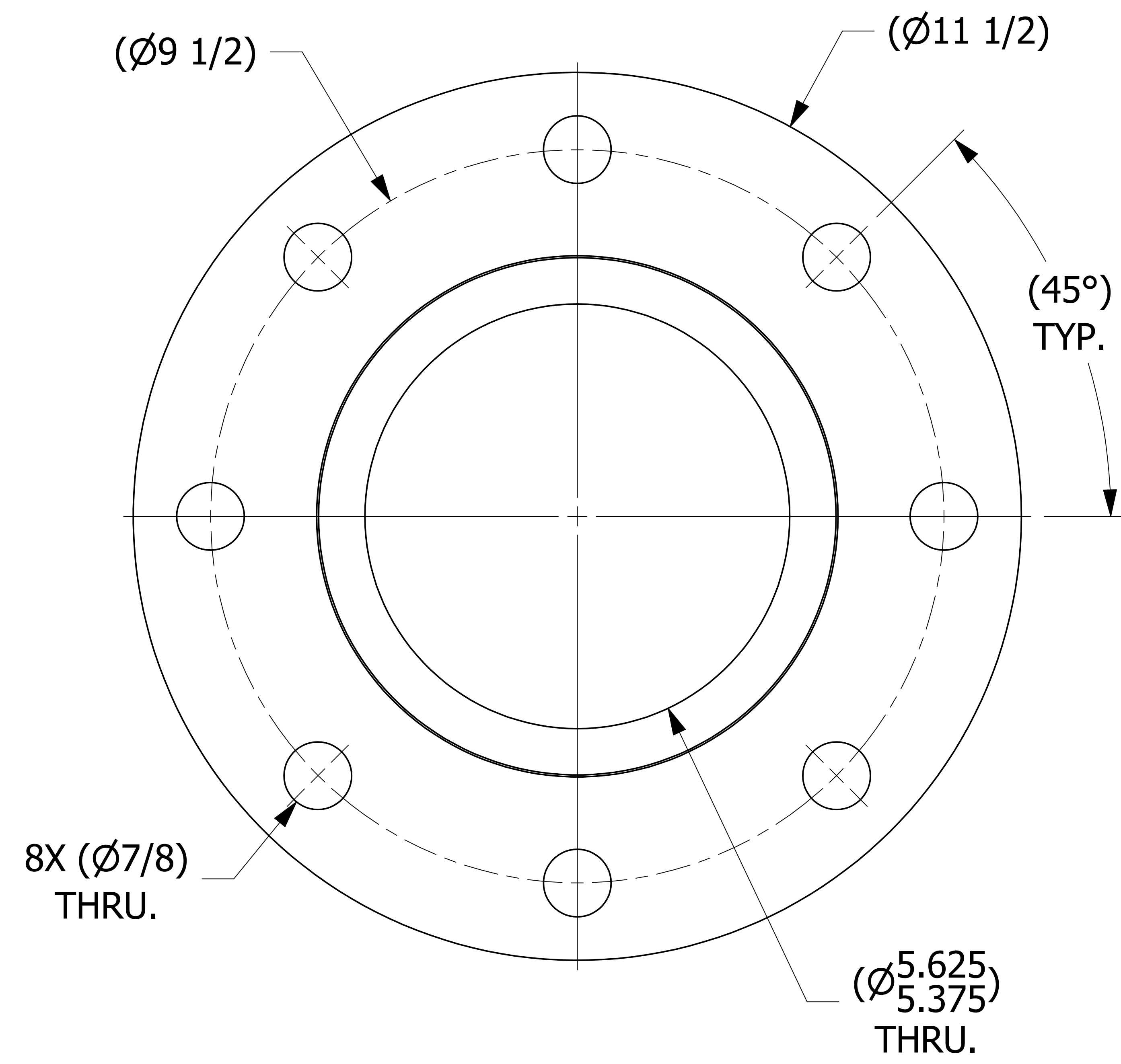

NOTE:
SOLD TO WORLEY WELDING ONLY.

E	GDS	9-29-11	REPLACED C26802 & B27209 WITH B31651
D	GDS	8-1-11	ADDED MARKING PRESSURE NOTE
C	VD	07-15-11	PART NUMBER WAS HS6DT9, REV. NOTES
B	REH	12-1-10	REPLACED HS6DTFL W/ HS6FLDGS
A	PJG	9-28-09	NEW PART ADDED TO SYSTEM
REV	BY	DATE	DESCRIPTION

<small>UNLESS OTHERWISE SPECIFIED DIMENSIONAL TOLERANCES</small> FRACTIONAL: $\pm 1/16$ X.XX: $\pm .03$ X.XXX: $\pm .015$ ANGULAR: $\pm 1^\circ$ DEBURR ALL SHARP EDGES. ALL MACHINED SURFACES TO HAVE A 125 RMS FINISH UNLESS NOTED OTHERWISE. THIRD ANGLE PROJECTION	DRAWN BY:	CHL
	CHECKED BY:	PJG
	PROTOTYPE BY:	CHL
	PROTOTYPE DATE:	7/17/2009
	APPROVED FOR PRODUCTION BY:	PJG
	PRODUCTION DATE:	9/28/2009

SALCO PRODUCTS, INC.

PART NAME: **PIPE STUB 6"**

MATERIAL: **SALCO PE**

PROJECT #: **090428** SHEET #: **1 OF 1** SCALE: **1:1**

DRAWING #: **E27211** PART #: **HS6PST9**